

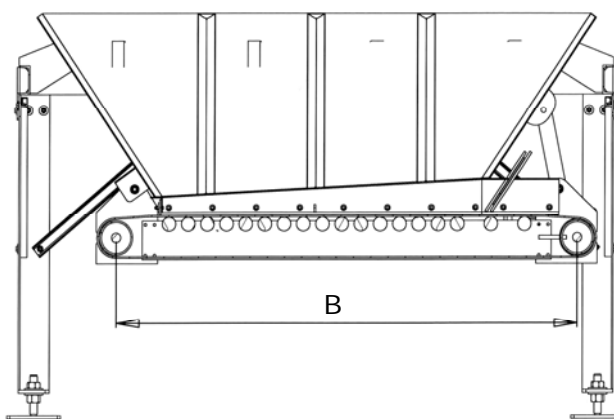

MAN ALIMENTATORE A NASTRO BELT FEEDER ALIMENTATEUR A BANDE

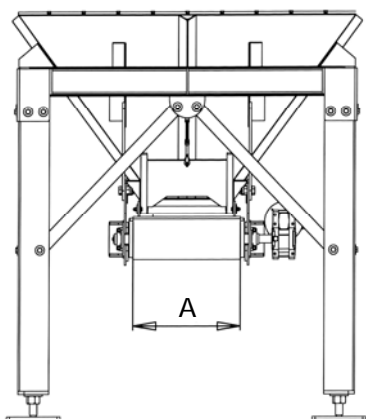

Modello Model Modèle	Larghezza nastro Belt width Largeur bande	Interasse tamburi Drums distance Entre-axes tambours	Portata Capacity Débit	Potenza Power Puissance	Peso Weight Poids
	A (mm)	B (mm)	(t/h)	(kW)	(kg)
MAN-040-130	400	1300	60	1,1	210
MAN-040-180	400	1800	60	1,5	290
MAN-040-250	400	2500	60	1,5	410
MAN-050-130	500	1300	90	1,5	260
MAN-050-180	500	1800	90	2,2	360
MAN-065-130	650	1300	200	2,2	340
MAN-065-180	650	1800	200	3	470
MAN-080-180	800	1800	300	4	580
MAN-100-180	1000	1800	450	4	730
MAN-100-420	1000	4200	450	7,5	1680

I DATI SOPRA RIPORTATI NON SONO IMPEGNATIVI E POSSONO SUBIRE VARIAZIONI SENZA PREAVVISO.
THE ABOVE DATA ARE NOT BINDING AND THEY CAN BE ALTERED WITHOUT NOTICE.
LES DONNÉES SUS-INDIQUÉES NE COMPORTENT AUCUN ENGAGEMENT ET PEUVENT ÊTRE CHANGÉES SANS PRÉAVIS.